

intelligent
closing
solutions



Ultra fast:
60-80 pck/min



ICS 500

Automatic carton closing machine

High performance that keeps pace with the packaging line



Fully automatic position adjustment of the sealing band



Can be used in industrial environments as standalone & integrated in the network.



Modern packaging and sealing technology



ICS 500 Automatic carton closing machine

LABELLING, CLOSING & SEALING IN ONE STEP

On the ICS 500 TopWrap carton sealer, trays filled with apples are taped and sealed from the top. The different trays, apple sizes and sealing bands are detailed below.

The ICS 500 carton sealing machine seals a wide variety of pack sizes with sealing bands. It convinces by a high output. It can be used in connection with a packaging line or stand-alone.

Quality: Innovative, market-driven labelling and sealing solutions at a high technical level with state-of-the-art production technology as well as absolute reliability and cost-effectiveness.

Hygiene: Hygienic design throughout, which is easy to clean. This fulfils all the requirements of the food industry.

Precision: Perfect results with optimal product presentation; the sealing bands are positioned precisely and securely.

Performance: We ensure that your closure system keeps pace with your packaging line. Servo drives and process-controlled motion sequences ensure high performance.

Cost-effectiveness: A high level of reliability and durability, minimal set-up times and the greatest possible freedom from maintenance increase productivity.

intelligent
closing
solutions

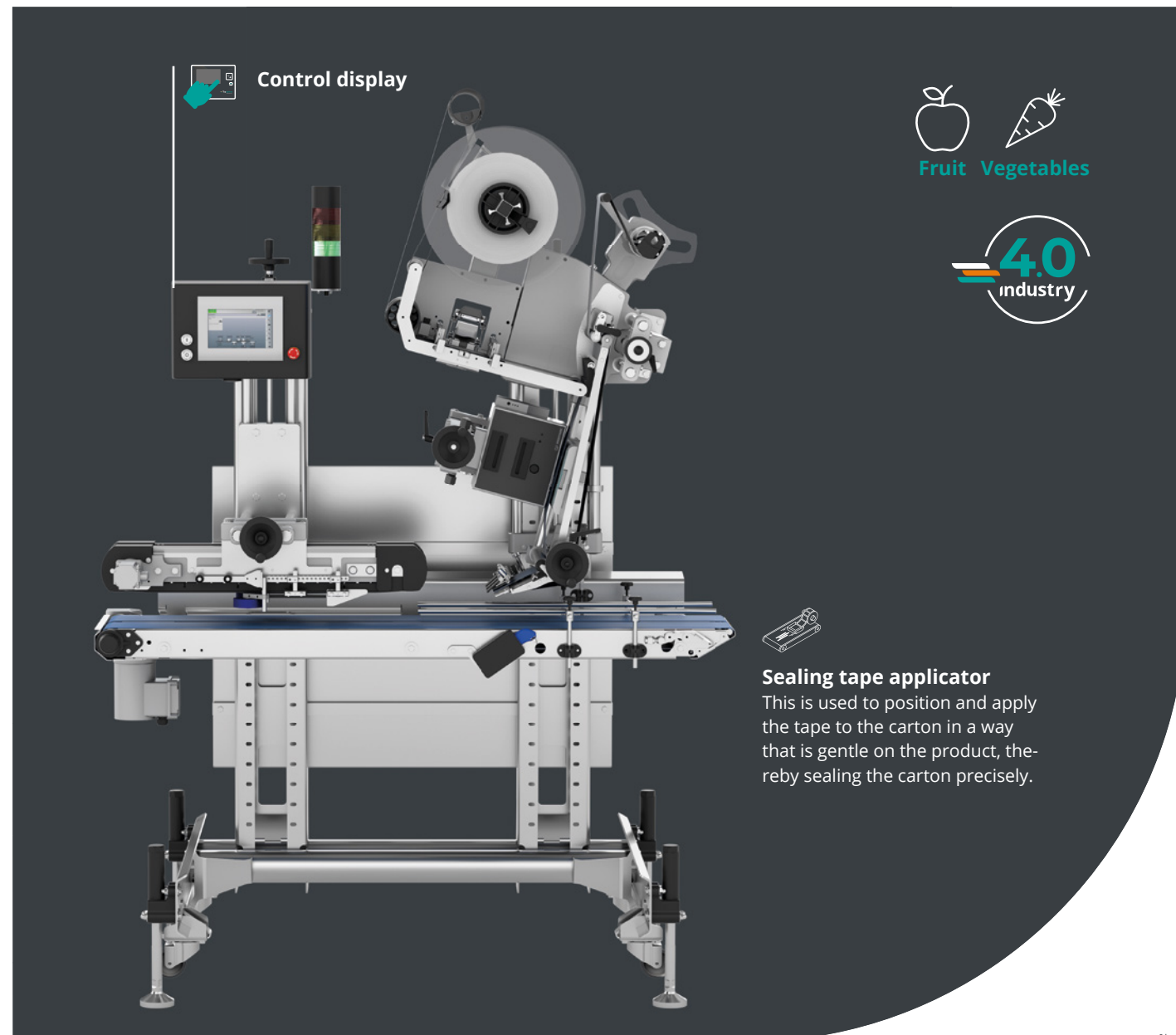
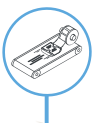

 Control display

 
Fruit Vegetables

4.0
industry



Sealing tape applicator

This is used to position and apply the tape to the carton in a way that is gentle on the product, thereby sealing the carton precisely.

HIGHLIGHTS



Precisely positioned application for optimum product presentation



High performance that keeps pace with the packaging line



Economical, reliable and durable



Quality, precision and efficiency



Hygienic construction



Maintenance-free System



Easy & quick change of the sealing tape rolls



Simple and intuitive operation

TECHNICAL PROPERTIES

Labelling capacity	60- 80 packs/minute (depending on pack and product characteristics)
Sealing tape dispenser	Ribbon dispenser with servo drive, digital motor feedback and thermo sensor Protection class: IP54 Interfaces: USB, EtherCAT, CAN and Ethernet Sealing tape speed: max. 120 m/min (depending on application) Tape length: min. 10 mm / max. 400 mm Tape width: min. 20 mm Position accuracy (dispensing edge): +- 0.3 mm (depending on tape material, speed, etc.)
Closure tape width	20 - 300 mm
Roll core diameter	76 mm
Unwinding device for tape rolls	380 mm Durchmesser
end of roll control / end of roll warning	Monitoring of the end of the tape. Pre-warning in case of small reel diameter
Thermal transfer printer optional	Markem SD X45 (53mm)

Band steering	Tape deflection (Top Wrap) incl. lateral silicone rollers. Format set for folding over the closure tapes.
Packing size (W/L/H)	Tray width at the base: 125 mm to 170 mm Tray length at the bottom: 125 mm to 220 mm
Direction of travel	right/left or left/right
Control unit	User interface HMI 2.0 Intuitive, colour 7" TFT touch screen (800x480 pixels) Graphical user guidance & clear menu structure in more than 30 languages; multi-level access rights management
Interfaces	USB and Ethernet interface
Operating temperature	0-30° C
Humidity	25 - 85 % r.h. non-condensing
Mains voltage	400 V 50/60 Hz . L1/L2/L3/N/PE
Power	max. 2KW
Device design	Stainless steel multi-column frame / size M Machine feet / height adjustment range 50 mm



Lamellar belt

Headgear design with slat belts to compensate for height differences up to approx. 10 mm. Specialised for use with apples.

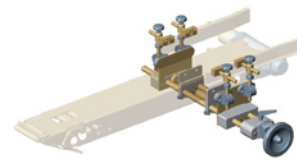

Feeding rails

Synchronous adjustment of the feed rails incl. Siko counter.



Products

Apples: diameter 60 - 90 mm, typical: 70 mm - 80 mm Divided into classes mostly in 5 mm steps. It is always packed per class

Example:

Setup 1: Apples 65 - 70 mm - Setup 2: Apples 70 - 75 mm

Setup 3: Apples 75 - 80 mm - Setup 4: Apples 80 - 85 mm



Punnets

Apple tray for 4 and 6 without flap
Tray width at the base: 125 mm to 170 mm
Length of tray at base: 125 mm to 220 mm

Optionally also available for 4, 6, 8-piece trays with flap.

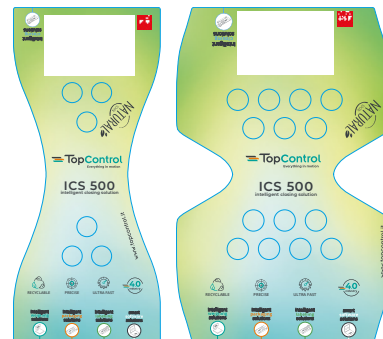

Label Tray-apple

Width: max. 295 mm
Length: max. 180 mm

OPC interface

For further processing of machine data on SCA-DA - PDA - systems, in the company network or on external PC (optional)

Antistatic unit

To prevent the dispensing process from being affected by electrostatic charging of the labels. (optional)

Technical drawings

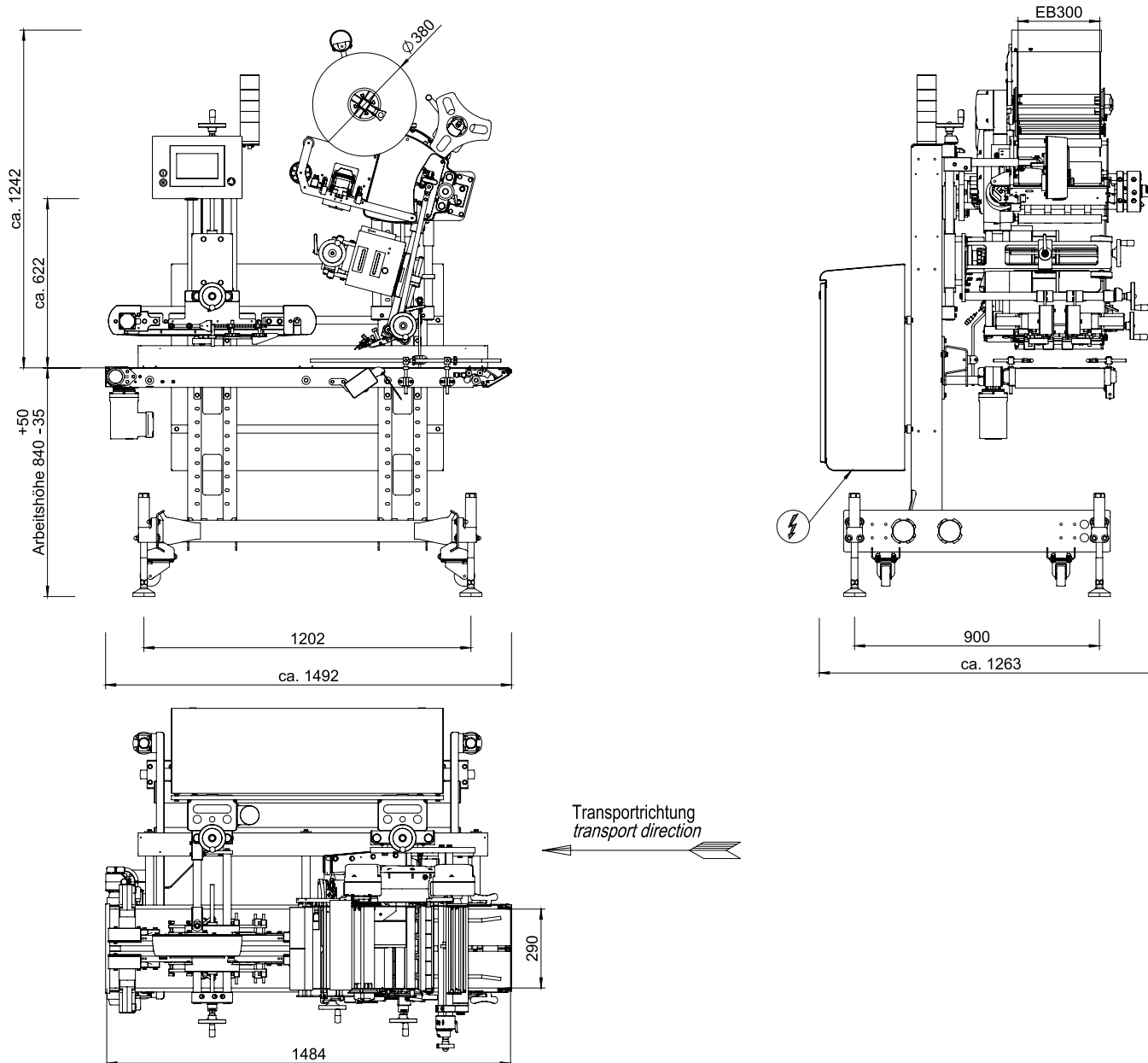

Output 60-80
pack/min. **

*height adjustable
** depending on pack size and speed of the preceding station.



SSC 9200
Levelling scale



RSC 9200
Removal scale



IWS 3000
Smart weighing table



MHP 1000
Combination scale



MHP 1200
Combination scale



MHP 1300
Combination scale



MHP 2000
Combination scale

intelligent weighing solutions



MHP 2100
Combination scale



MHP 3000
Combination scale



MHP 5200
Automatic multibelt scale



CWT 1000
Automatic checkweigher



CWT 500
Automatic checkweigher for transport packaging



ST A500B
Automatic checkweigher for transport packaging



ST EPW310
Dynamic scale for bags

intelligent labelling solutions

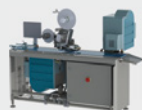

GLM-B-S
High-performance labeller



ILS 3000
Labeller for transport packaging



GLT maxx 9000
Labeller for transport packaging



GPH maxx 7-8-9000
Pallet labeller



ILS 3800
Pallet labeller

intelligent closing solutions



ICS 1000
Automatic gluing machine for carton packs

intelligent packaging solutions

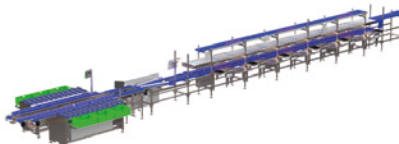

IPS: Line with 4 levels and front weighing tables and MHP 3000 semi-automatic combination scale



IPS: Line with 4 levels and front weighing tables, automatic checkweigher and labeller



IPS small: Line with 2 levels and front weighing tables and automatic checkweigher

smart software solutions

