

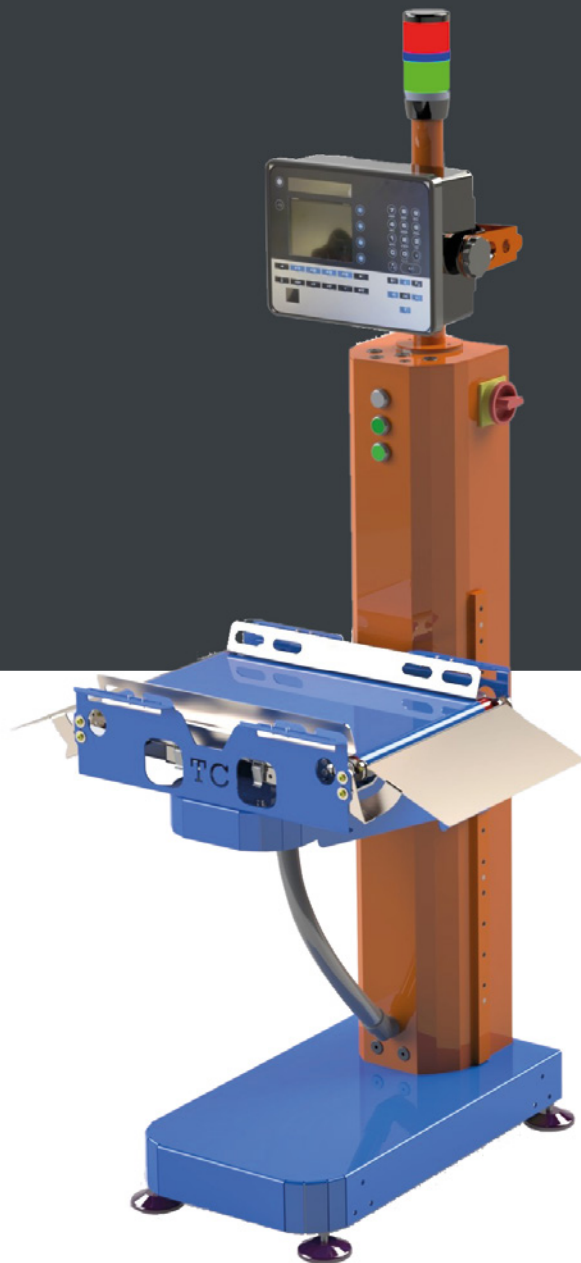

intelligent
weighing
solutions

 **TopControl**
Everything in motion



ST-EPW 310B
**Dynamic
checkweigher**

Maximum packaging speed



Profit maximisation



ROI within 3-12 months



Dynamic weight limit control



ST-EPW 310B Dynamic Checkweigher

The dynamic checkweigher ST-EPW 310B checks packages of fruit and vegetables that are delivered in bags and nets. The checkweigher produced by TopControl was designed for a perfect weight control and as a reliable processsteering device in the food industry. Due to its great adaptability and flexibility, it meets easily, quickly and cost effectively all requirements for weight control of bags or nets.

The weight check is carried out by means of an automatic scale, where all packs are automatically reweighed, so-called 100% check.

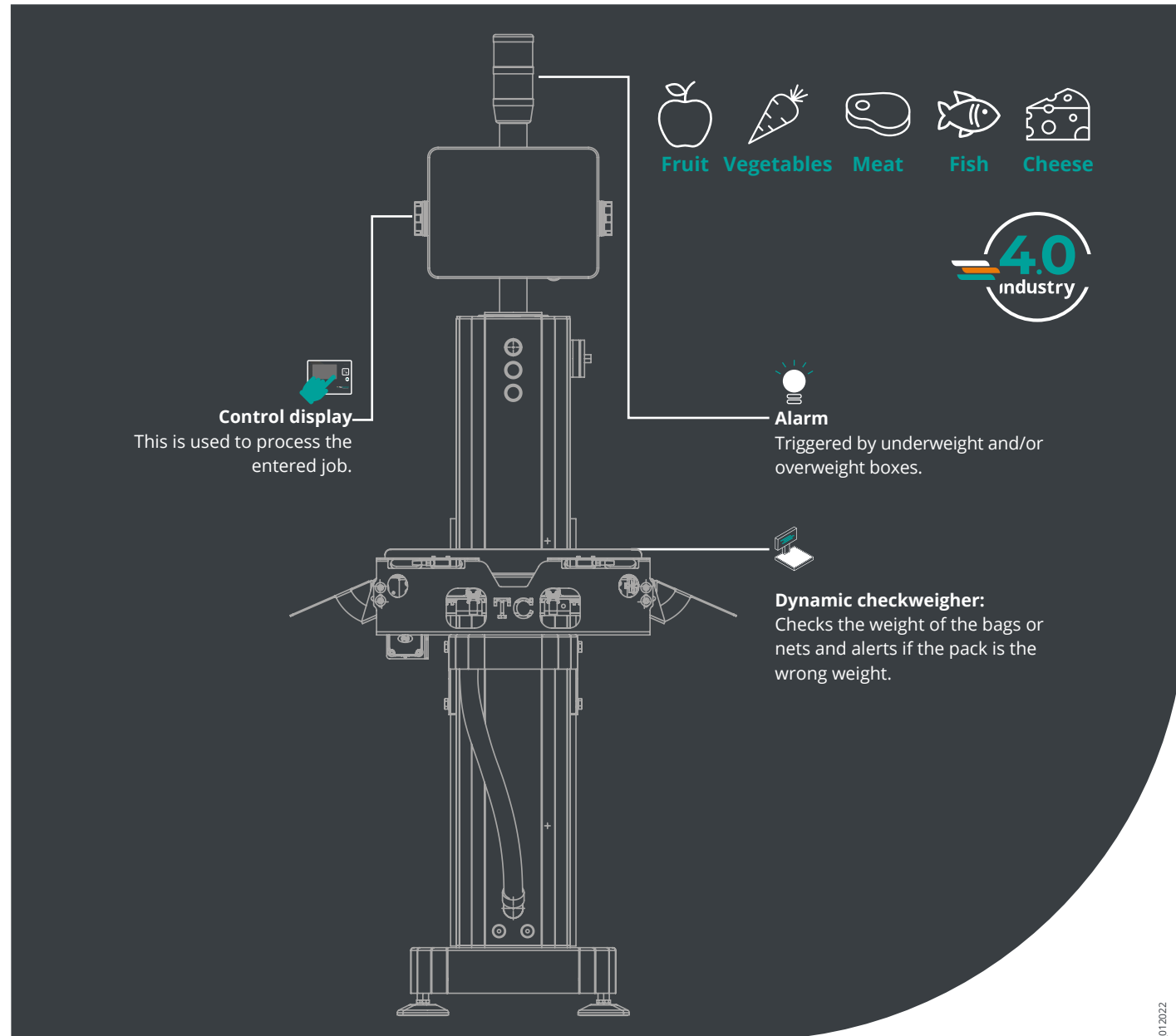

HIGHLIGHTS



Adjustable transport speed



Profit maximisation



ROI within 3-12 months



Robust industrial design



Display rotatable



Easy operation



Operating mode: dynamic



Compact Design



Flexible applicable

TECHNICAL PROPERTIES

Throughput	30 Pack/min. (depends on the weight and the infeeding speed)
Weight range/division	15kg/5g
Dimensions of weighing conveyor (LxW)	500 x 300 mm
Operating mode	dynamic
Interfaces	Ethernet 10 base T, Tcp/IP, RS 232, RS 422
Protection	IP54
Height adjustment	470 mm bis 1000 mm
Framee	stainless steel or powder coated

Automatic scale for single weighing according to guideline 2004/22/Eg annex Mi-006: with Eg-type examination certificate (MiD)

Ejection system (*optional)

The ejection system for faulty packs (pusher) is available on request. Other variants can also be realised on request.

Height adjustment (*optional)

The additional height adjustability allows the checkweigher to be adapted to the line: 470 mm to 1000 mm

ST-EPW 310B Dynamic Checkweigher

Technical drawings

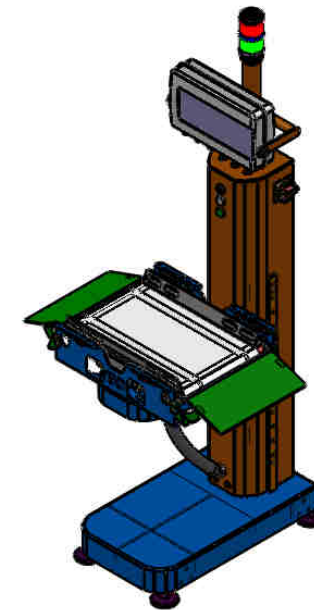
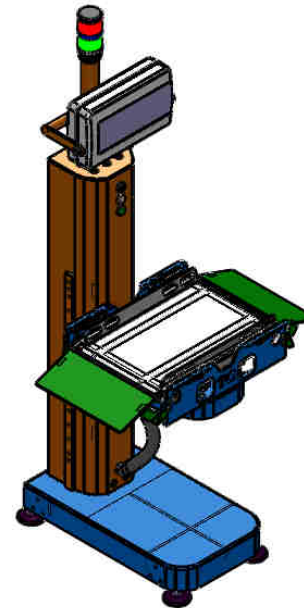
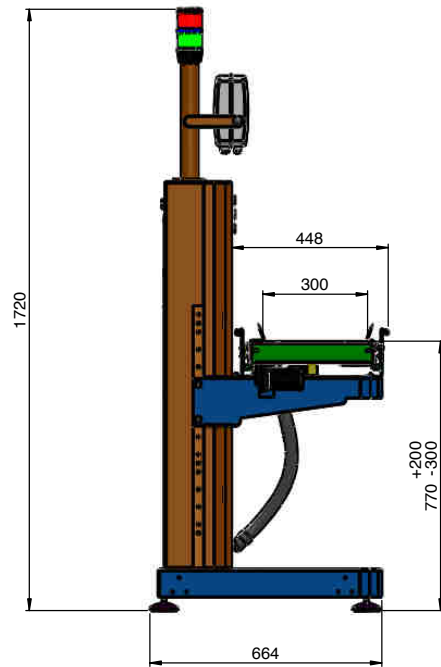
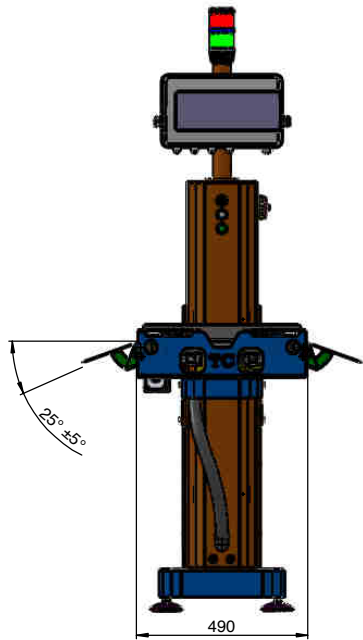

Optimised for products packed in bags and nets.

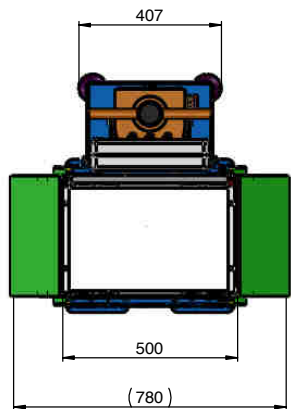

*ergonomically height adjustable
470 mm to 1000 mm



SSC 9200
Levelling scale



RSC 9200
Removal scale



IWS 3000
Smart weighing table



MHP 1000
Combination scale



MHP 1200
Combination scale



MHP 1300
Combination scale



MHP 2000
Combination scale



MHP 2100
Combination scale



MHP 3000
Combination scale



MHP 5200
Automatic multibelt scale



CWT 1000
Automatic checkweigher



CWT 500
Automatic checkweigher for transport packaging



ST A500B
Automatic checkweigher for transport packaging



ST EPW310
Dynamic scale for bags

intelligent weighing solutions

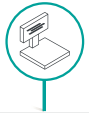

intelligent labelling solutions

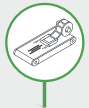

GLM-B-S
High-performance labeller



ILS 3000
Labeller for transport packaging



GLT maxx 9000
Labeller for transport packaging



GPH maxx 7-8-9000
Pallet labeller



ILS 3800
Pallet labeller

intelligent closing solutions



ICS 1000
Automatic gluing machine for carton packs

intelligent packaging solutions

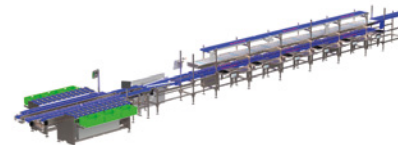
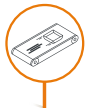

IPS: Line with 4 levels and front weighing tables and MHP 3000 semi-automatic combination scale



IPS: Line with 4 levels and front weighing tables, automatic checkweigher and labeller



IPS small: Line with 2 levels and front weighing tables and automatic checkweigher

smart software solutions

