



intelligent  
**weighing**  
solutions



RSC 9200  
**Removal scale**

Increase in productivity by more than 50%



Maximum reduction of giveaway



Optimized and gentle packaging process



Mobile and ergonomic construction



**Precise weighing creates the conditions for an optimal, efficient, fast and simple packing process.**

The high-resolution removal scale RSC9200 ensures exactly this: using the principle of picking out a total amount of goods, allows to portion optimal units of products. From the box on the scale the predefined partial quantity is removed and placed in the sales packaging. An intuitive touch display helps the operator to portion quickly and accurately to the gram. This reduces the giveaway to a minimum and enables an increase in productivity by 50%.

As a result, it is possible to achieve a halving of the packing times and a significant increase in the weighing accuracy of products from the food industry. The personnel time recording of the employees is carried out simply by registering on a transponder reader integrated in the scale. Integrated into the WLAN network, each scale transmits the weight data and personnel time to the central TopControl software.

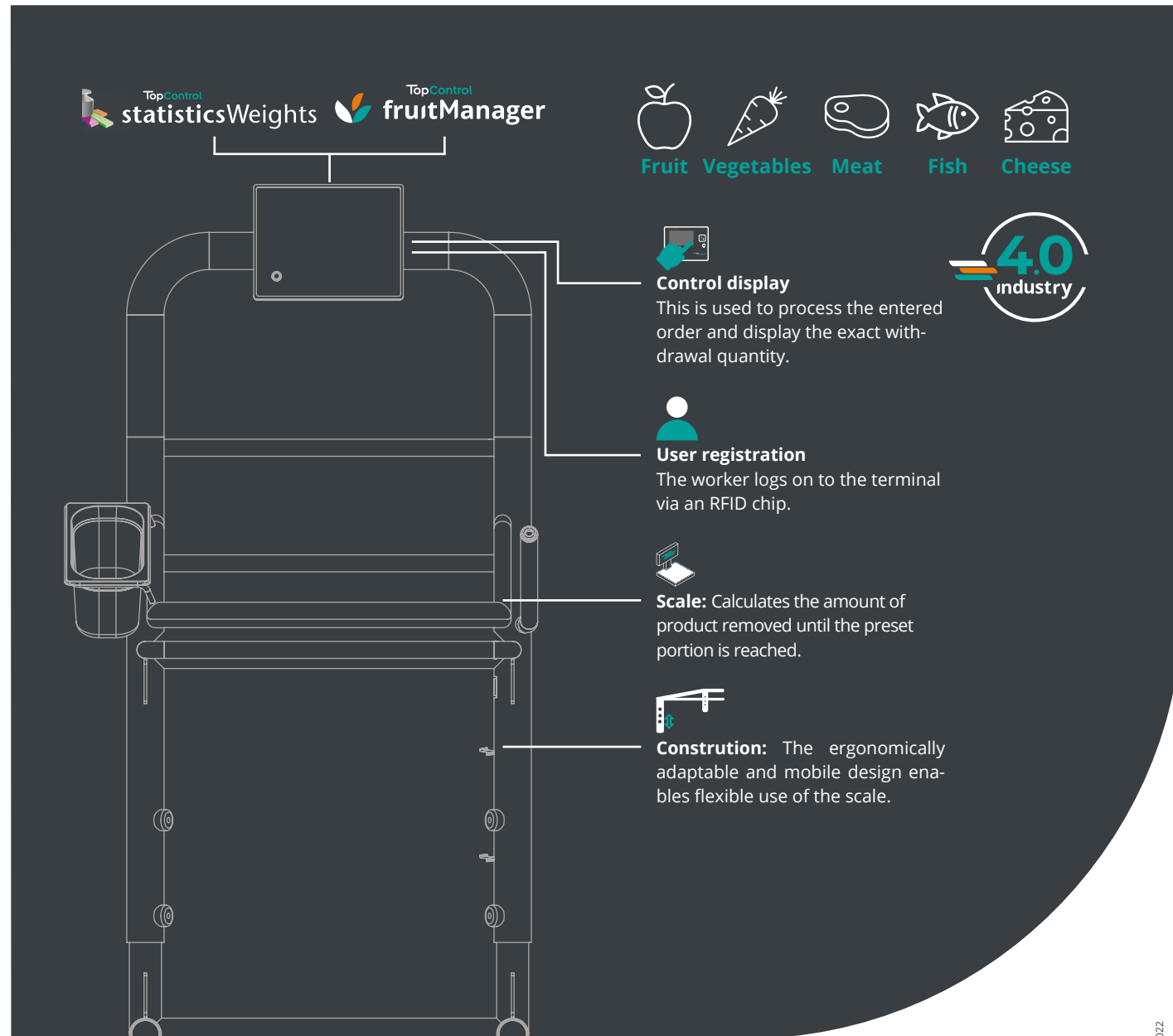

## HIGHLIGHTS



Increase in productivity by more than 50%



Profit maximization



ROI within 3-12 months



Increase in productivity by 50%



Mobile and ergonomic construction - IP67



Easy integration into the packaging process



Packing according to WELMEC 6.4/e for pre-packed goods



Dynamische Gewichtsgrenzregelung



Intuitive touch display with integrated transponder reader for working time recording



Equalising or withdrawal weighing can be defined per article



Complete control and registration of weight and performance data through the TopControl software

## TECHNICAL PROPERTIES

|  |  |
|--|--|
| Dimension (L/W/H)                            | 889 mm x 1042 mm x 1595 mm (+250 mm)                       |
| Load capacity/division                       | 20 kg/1 g - 30 kg/2 g                                      |
| Protection class                             | IP67   |
| Power supply                                 | 220V   |
| Interfaces                                   | Ethernet 10 base T, TCP/IP, RS 232, RS 422 und WLAN 2.4GHz |
| Maximum box size                             | 600x400x216 mm   |
| Display                                      | Colour LCD touch display 7 inch                            |
| (!) Non-verifiable scales - for internal use |  |

## Technical drawings

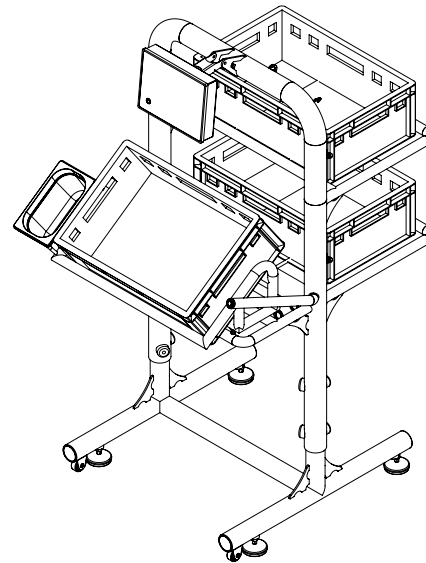
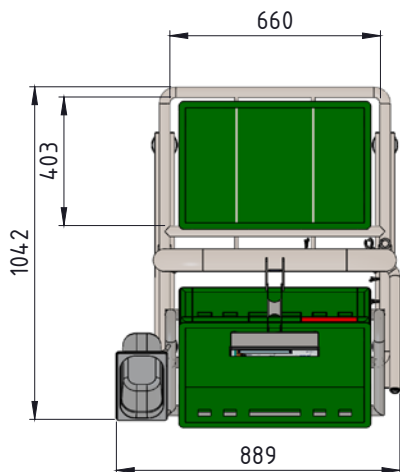
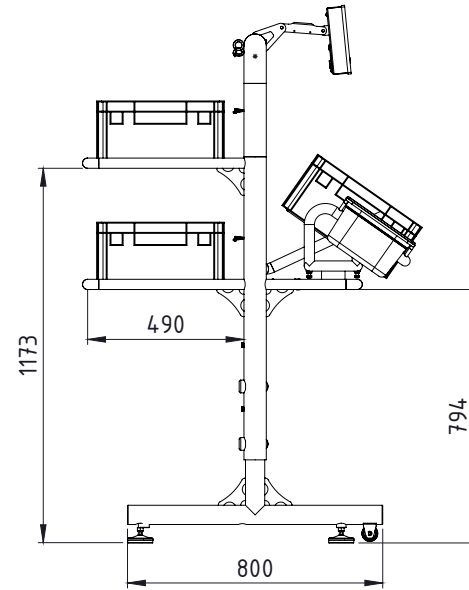
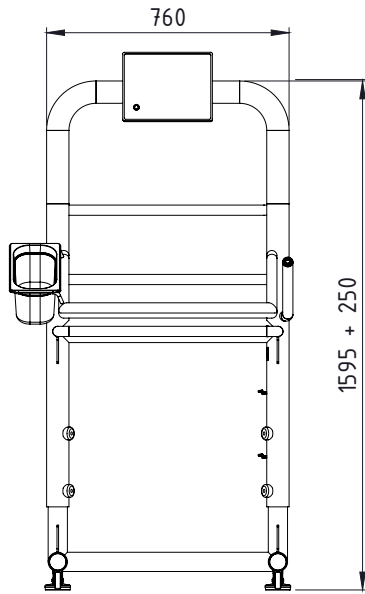

Optimised for herbs and light vegetables.



## Technical drawings

Optimised for herbs and light vegetables.

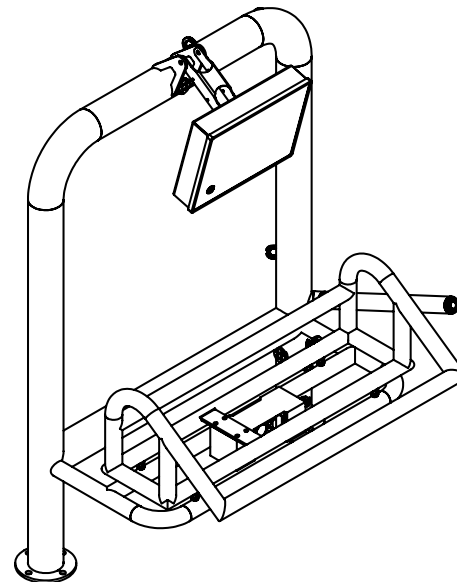
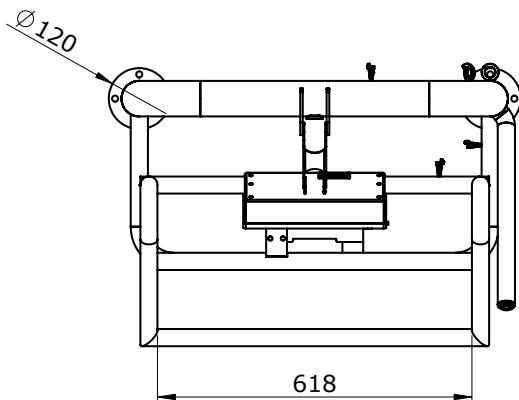
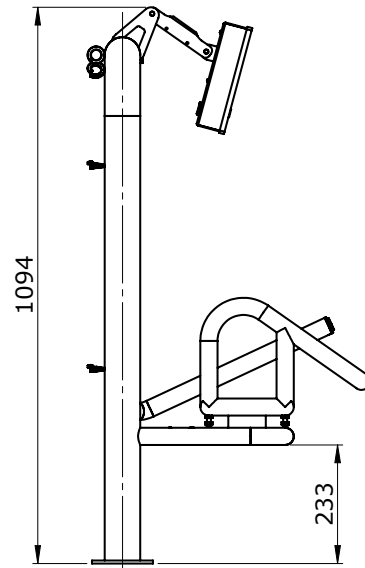
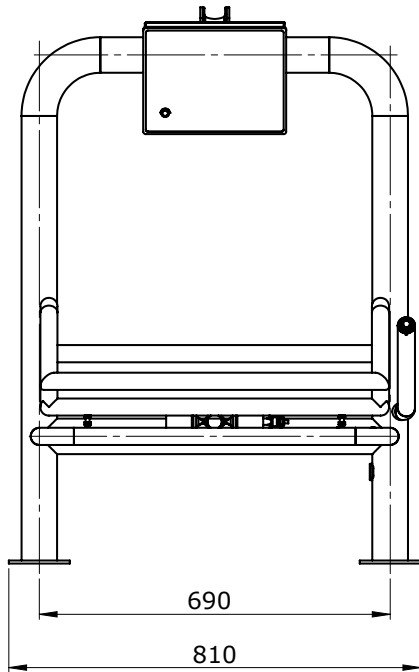

intelligent weighing solutions

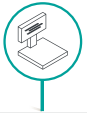

**SSC 9200**  
Levelling scale



**RSC 9200**  
Removal scale



**IWS 3000**  
Smart weighing table



**MHP 1000**  
Combination scale



**MHP 1200**  
Combination scale



**MHP 1300**  
Combination scale



**MHP 2000**  
Combination scale



**MHP 2100**  
Combination scale



**MHP 3000**  
Combination scale



**MHP 5200**  
Automatic multibelt scale



**CWT 1000**  
Automatic checkweigher



**CWT 500**  
Automatic checkweigher for transport packaging



**ST A500B**  
Automatic checkweigher for transport packaging



**ST EPW310**  
Dynamic scale for bags

intelligent labelling solutions



**GLM-B-S**  
High-performance labeller



**ILS 3000**  
Labeller for transport packaging



**GLT maxx 9000**  
Labeller for transport packaging



**GPH maxx 7-8-9000**  
Pallet labeller



**ILS 3800**  
Pallet labeller



intelligent closing solutions



**ICS 1000**  
Automatic gluing machine for carton packs

intelligent packaging solutions

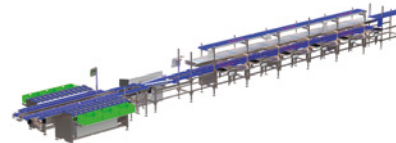

**IPS:** Line with 4 levels and front weighing tables and MHP 3000 semi-automatic combination scale



**IPS:** Line with 4 levels and front weighing tables, automatic checkweigher and labeller



**IPS small:** Line with 2 levels and front weighing tables and automatic checkweigher

smart software solutions

