



intelligent
weighing
solutions



SSC 9200
System scale

Optimise the giveaway and maximise productivity



Maximise profit



ROI within 3-12 months



Dynamic weight limit control



SSC 9200 Levelling scale

The weighing scale SSC9200 optimizes the giveaway of the packed goods.

Integrated in the network, the weights are recorded directly in the central TopControl software.

The intuitive LED display integrated in the display facilitates fast, accurate packing of the products. This avoids overweight and consequently less product is wasted in the packaging process. The high accuracy and speed of the scales and the ease of use allow significant savings.

Productivity is noticeably increased. The production process is traceable and analysable.

TopControl
statisticsWeights

TopControl
fruitManager



Control display

This is used to process the entered job.



User registration

The worker logs on to the terminal via an RFID chip.



LED

Indicates reaching the appropriate weight.



Weighing platform: Calculates the optimum weight to keep the giveaway as low as possible.

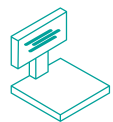

HIGHLIGHTS



Recording of input batches and waste quantity



Profit-maximisation



ROI
3-12 month



Maximum productivity through intuitive LED display



Giveaway optimisation



Dynamic weight limit control



Packing according to WELMEC 6.4/e for pre-packed goods



Intuitive touch display with integrated LED display



Efficient working time recording through integrated transponder reader



Equalising or withdrawal weighing can be defined per article



Complete control and recording via the TopControl software

TECHNICAL PROPERTIES

Weighing platform - Sizes	250 x 250 mm 300 x 300 mm 350 x 350 mm 400 x 700 mm with roller conveyor
Power supply	Power supply unit 24V
Electrical power	10W
Protection class	IP65
Interface	WLAN 2.4GHz
Colour LCD touch display	3,2 inch display
Operating languages	DE - IT - EN - ES - CS - FR - SK
(!) Non-verifiable scales for internal use	

WEIGHING RANGE

Weighing range	Measuring cell		Stand alone			with roller conveyor
	Alu	Inox	250 x 250 mm	300 x 300 mm	350 x 350 mm	400 x 700 mm
			Preload 2,5 kg	Preload 3,5 kg	Preload 5,5 kg	Preload 3,2 kg
6kg / 1g	x	x	x	x	x	
15kg / 2g	x	x		x	x	
20kg / 5g	x			x	x	
30kg / 5g		x			x	
15 kg / 5g	x					x
30 kg / 10g	x					x

Version	Terminal		Montage Terminal			Wall Mount
	Portrait	Landscape	Centred to platform	Lateral to platform	Horizontal to platform	
Weighing platform 250 x 250 mm	X	X	X	X	X	X
Weighing platform 300 x 300 mm	X	X	X	X	X	X
Weighing platform 350 x 350 mm	X	X	X	X	X	X

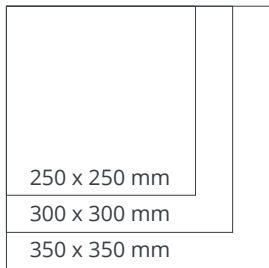

Weighing platform Measuring cells Weighing range

Depending on the application, the weighing platforms are available in aluminium or inox in the sizes 250 x 250 mm, 300 x 300 mm and 350 x 350 mm with different weighing ranges (see technical details).

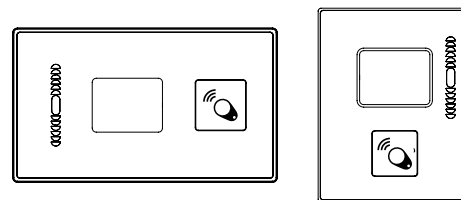

Terminal Display

The terminal can be connected to the network via LAN or WLAN and thus also to the TopControl software for order processing and analysis. The display convinces with its intuitive colour display combined with the LED bar with which the weight is displayed.

There are 2 versions of the terminal. Depending on the application, it is needed in portrait or landscape format.

The registration of the workers is done with a transponder directly at the terminal.

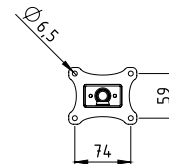

Wall mounting

Tripod Wall mount

The terminal can be mounted in different ways. There are stands in the variants small, middle and high on which the terminal can be mounted in portrait or landscape format, centred or sideways to the platform.

It is also possible to mount the vertical terminal lying next to the platform.

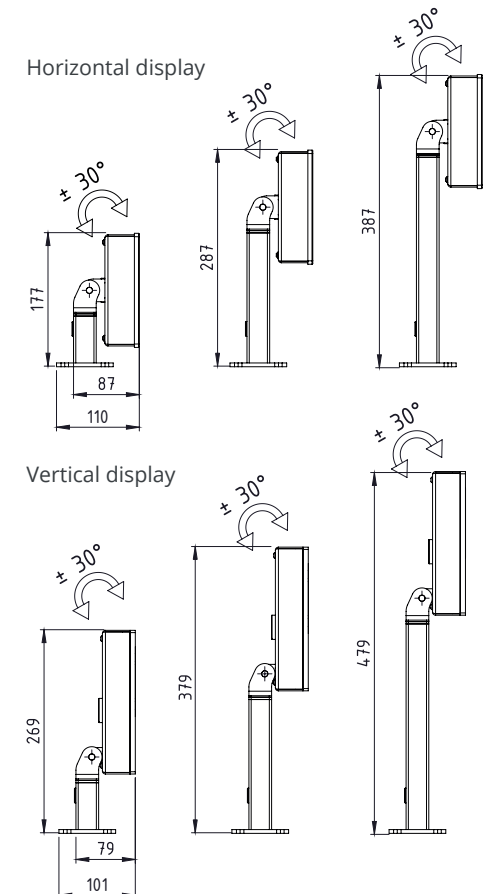

SSC 9200

Levelling scale as table scale with horizontal terminal

Technical drawings

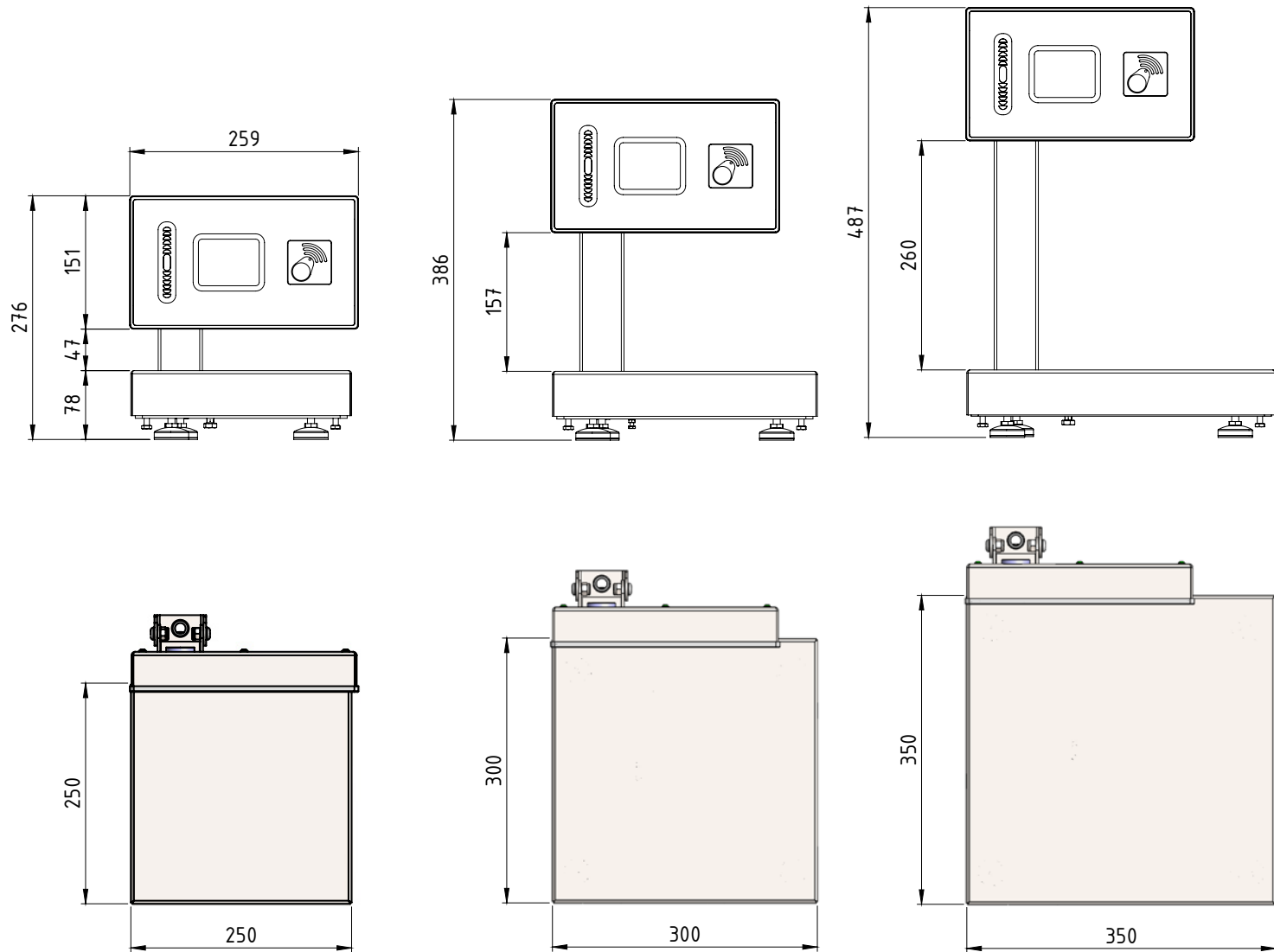

Optimised for medium-sized vegetables, fruit, cheese, meat and fish.



Fruit



Vegetables



Meat



Fish



Cheese

SSC 9200 Levelling scale as table scale with horizontal - displace terminal

Technical drawings

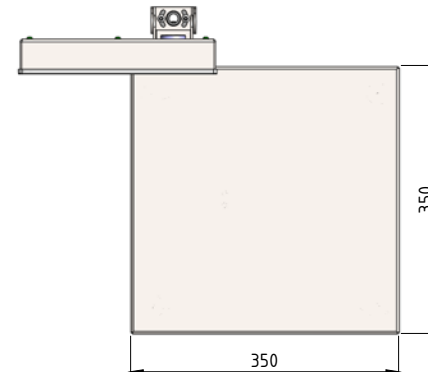
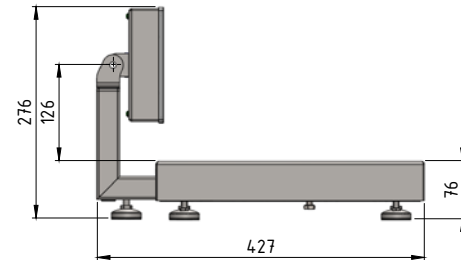
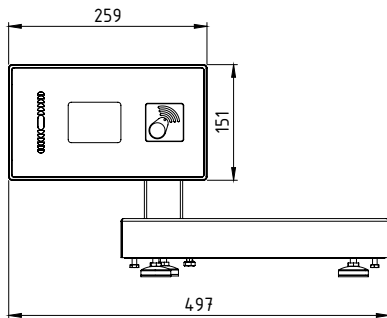
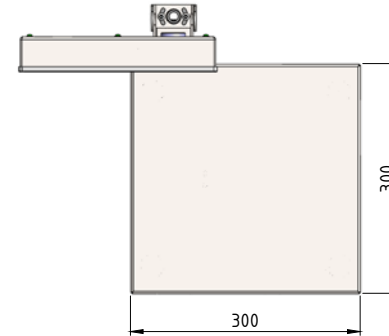
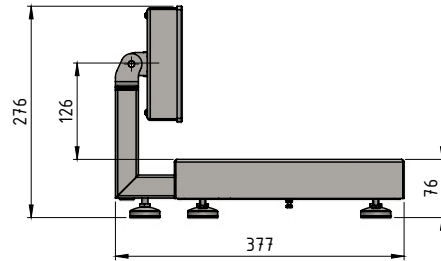
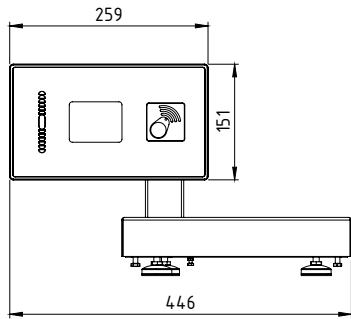

Optimised for medium-sized vegetables, fruit, cheese, meat and fish.



Fruit



Vegetables



Meat



Fish



Cheese

SSC 9200

Levelling scale as table scale with vertical - lateral terminal

Technical drawings

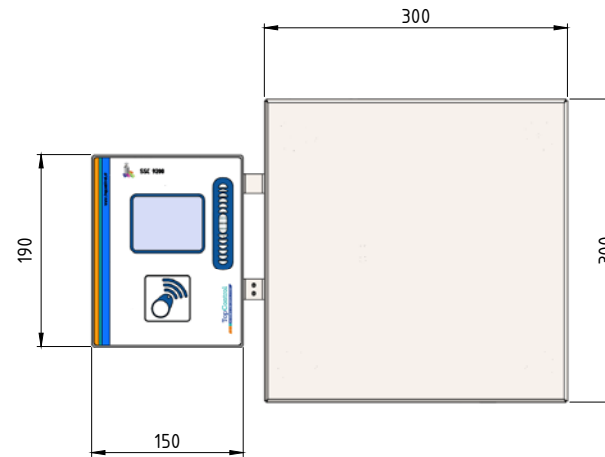
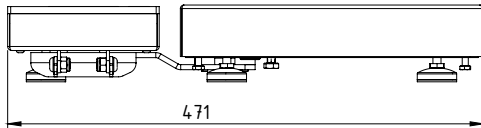
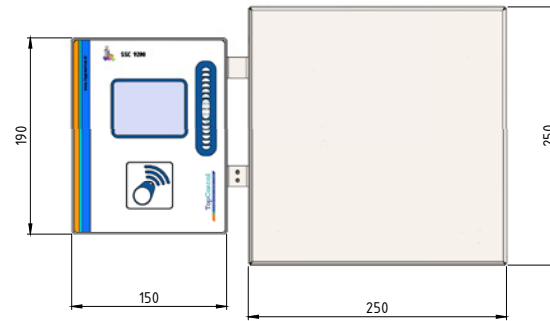
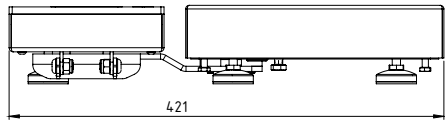

Optimised for medium-sized vegetables, fruit, cheese, meat and fish.



Fruit



Vegetables



Meat



Fish



Cheese

Technical drawings

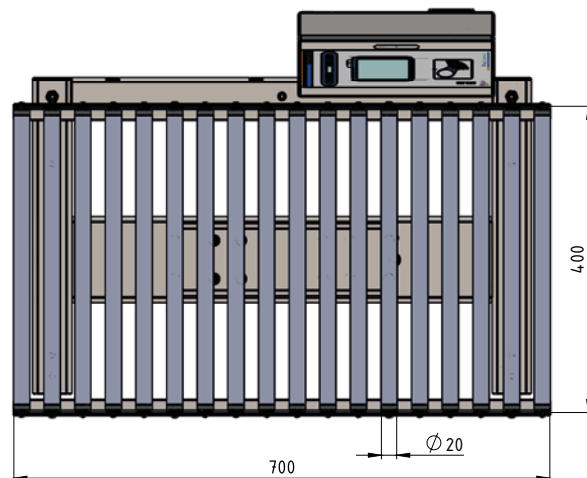
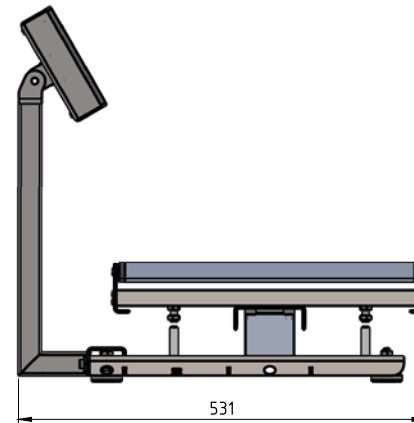
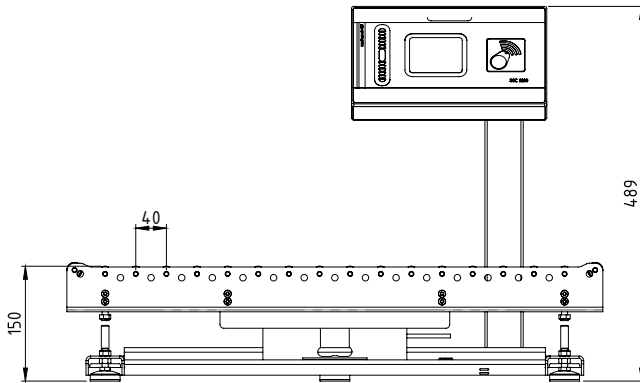

Optimised for medium-sized vegetables, fruit, cheese, meat and fish.



Fruit



Vegetables



Meat



Fish



Cheese

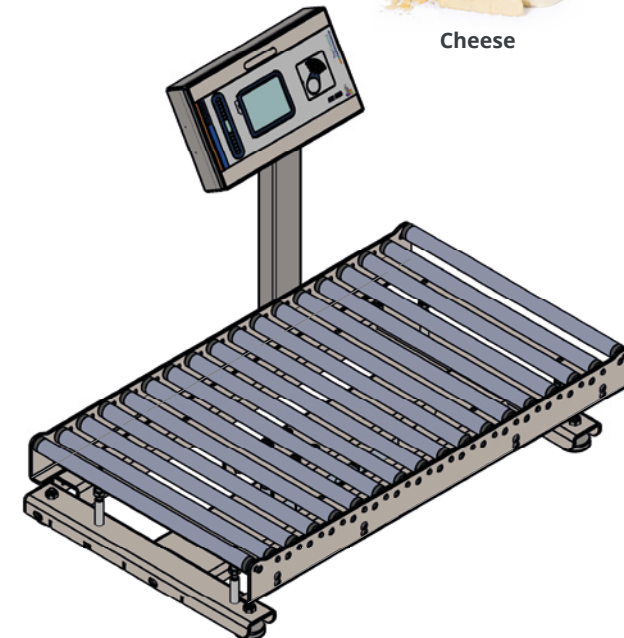



SSC 9200
Levelling scale



RSC 9200
Removal scale



IWS 3000
Smart weighing table



MHP 1000
Combination scale



MHP 1200
Combination scale



MHP 1300
Combination scale



MHP 2000
Combination scale



MHP 2100
Combination scale



MHP 3000
Combination scale



MHP 5200
Automatic multibelt scale



CWT 1000
Automatic checkweigher



CWT 500
Automatic checkweigher for transport packaging



ST A500B
Automatic checkweigher for transport packaging



ST EPW310
Dynamic scale for bags

intelligent weighing solutions

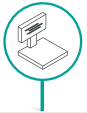

intelligent labelling solutions



GLM-B-S
High-performance labeller



ILS 3000
Labeller for transport packaging



GLT maxx 9000
Labeller for transport packaging



GPH maxx 7-8-9000
Pallet labeller



ILS 3800
Pallet labeller

intelligent closing solutions



ICS 1000
Automatic gluing machine for carton packs

intelligent packaging solutions

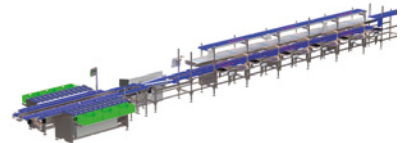

IPS: Line with 4 levels and front weighing tables and MHP 3000 semi-automatic combination scale



IPS: Line with 4 levels and front weighing tables, automatic checkweigher and labeller



IPS small: Line with 2 levels and front weighing tables and automatic checkweigher

smart software solutions

